

Reference Image for Product Usage

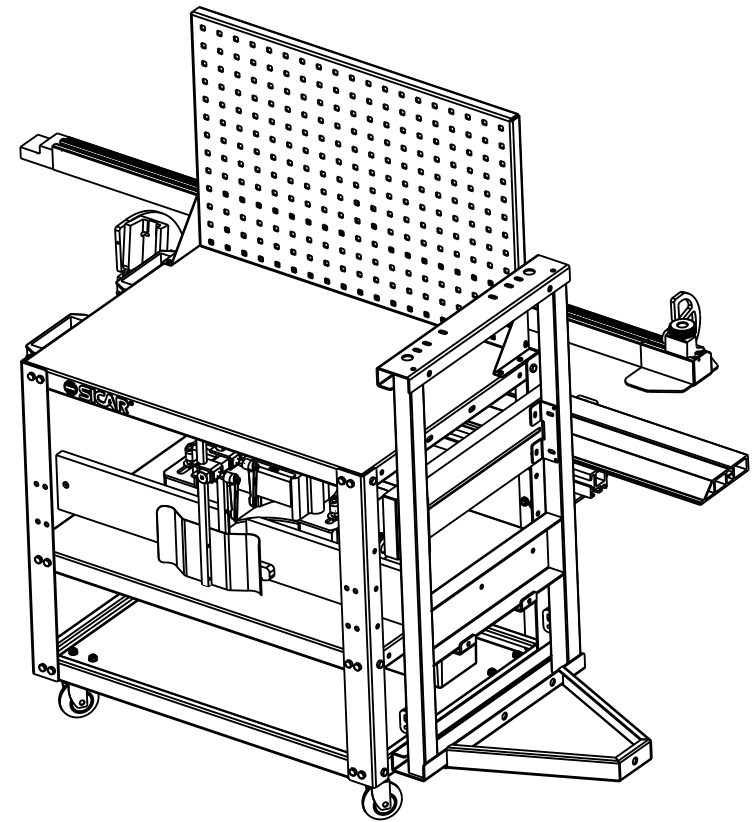

Auxiliary tool cart
For combined machine

Applicable to:
C300/C400/400B/400C/300C



Specially designed for combined machines, can store all machine components neatly, keeping them organized and easily accessible.



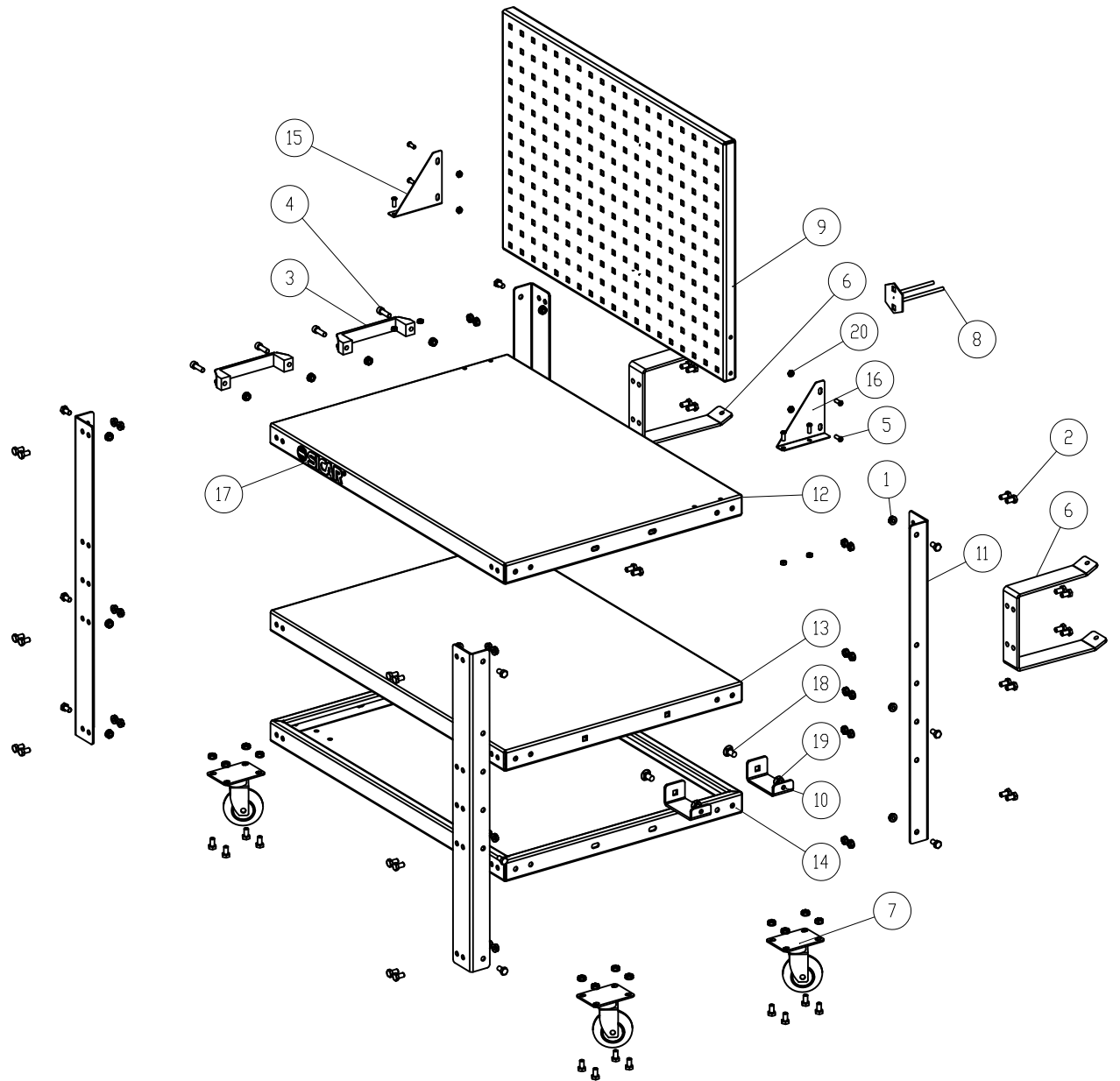
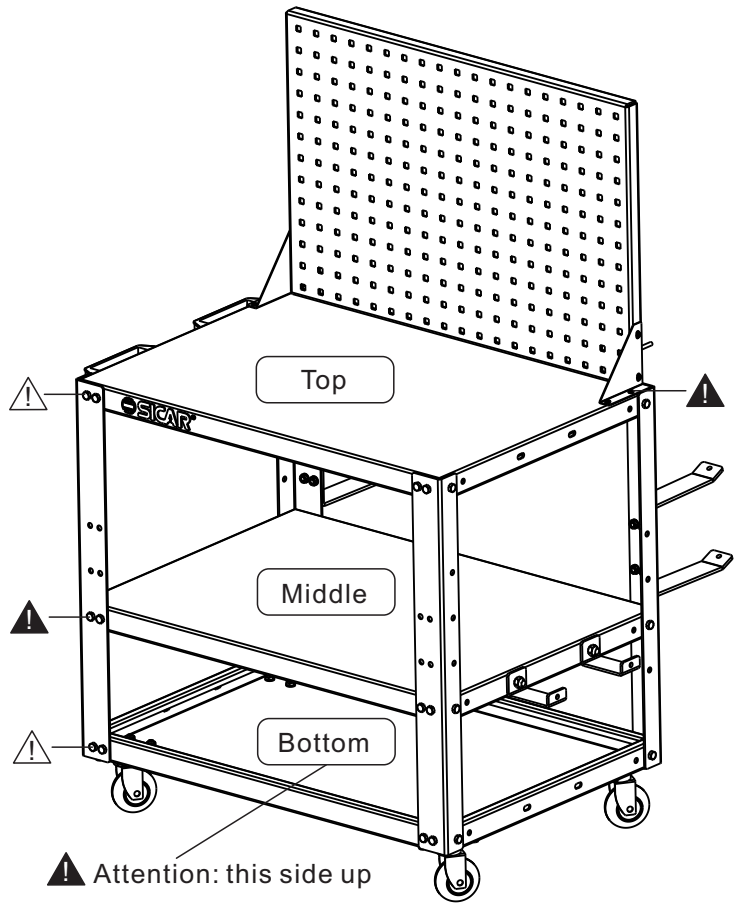

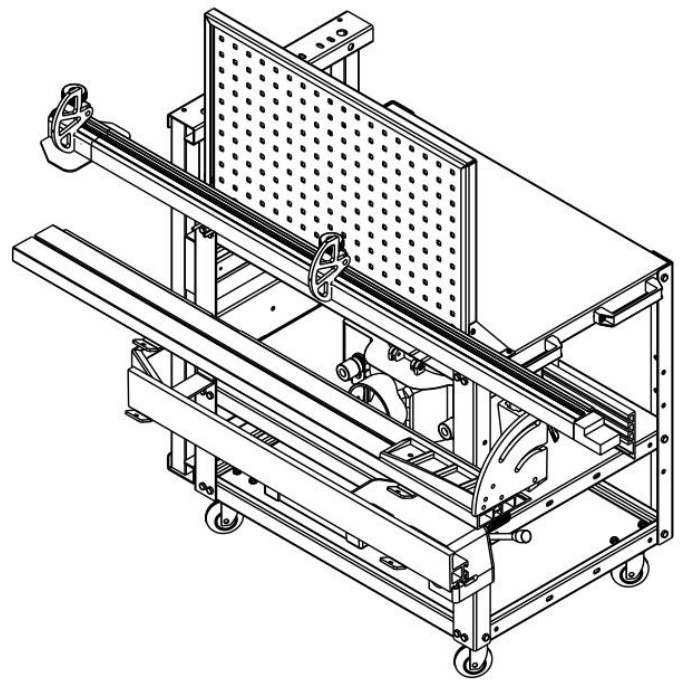
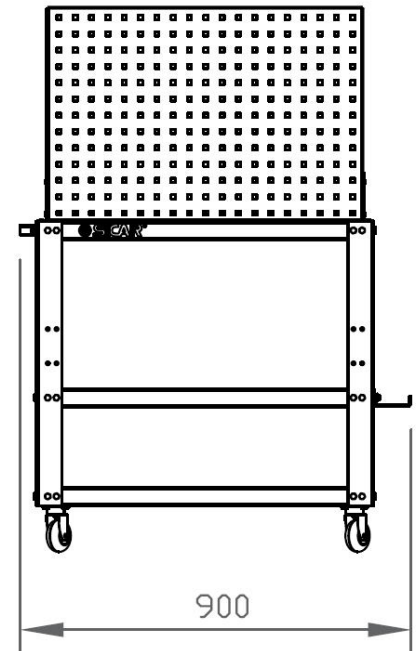
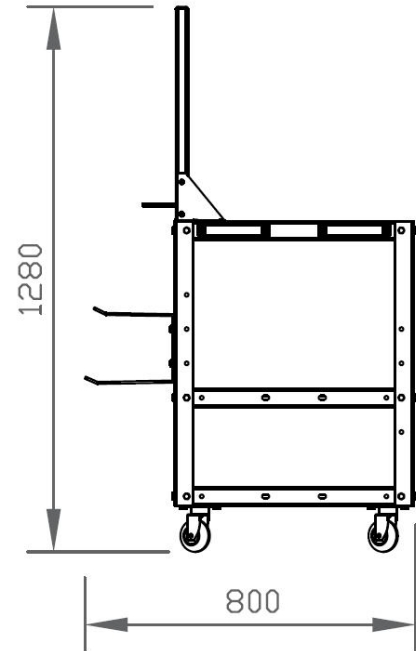
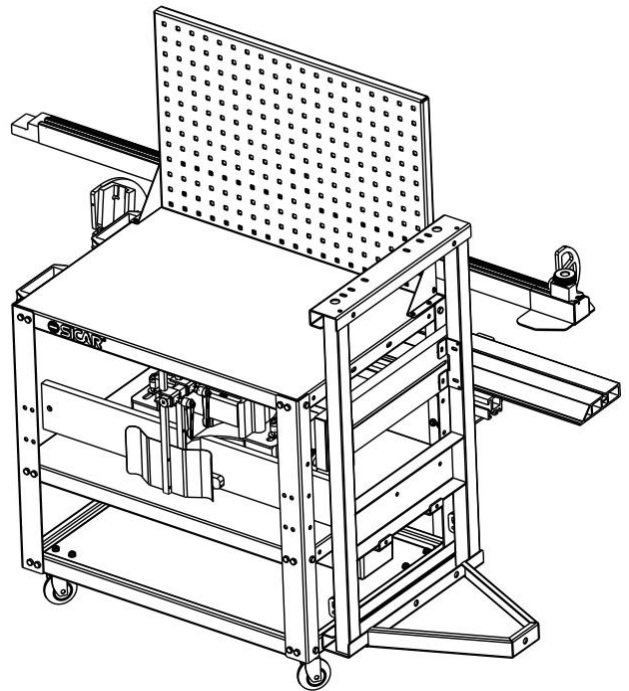
Assembly Guide Diagram



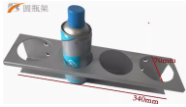
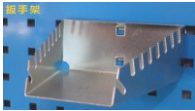

Auxiliary tool cart for Combined machine

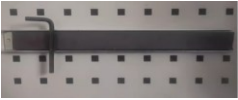
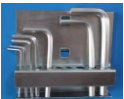
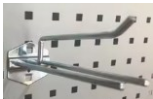
Model: SC9080-A

Item	Pic	Description	Qty.	Remark
1		Storage Cart	1	
2		Liquid Bottle Rack	1	Only bracket/stand; lubricating oil and spray not included.
3		Wrench Holder	1	
4		Single Slope 50mm	5	
5		Magnet Strip	1	
6		Hex Wrench Holder	1	
7		Pliers Hook	1	
8		Box Hanger Plate	2	

Item	Pic	Description	Qty.	Remark
9		Rod Bracket 60mm	2	
10		U-Shaped Hook 70*35	1	
11		100 Wire Guide	2	
12		Ring 60mm	1	
13		Ring 80mm	1	
14		No.1 Parts Box Blue	1	
15		No.2 Parts Box Blue	1	
16		Hook for rip-fence and X-cut fence	2	
17		Hook for X-cut frame	2	